

**Serie | 2, Fully-integrated dishwasher,
60 cm
SMV2HAX02G**



Optional accessories

- SGZ1010 : inlet and outlet hose extention
- SMZ5005 : Compensating + fixing kit, stainl. steel
- SMZ5035 : Decor conversion kit, stainless steel
- SMZ5300 : GlassSecure Tray

Easy loading of dishes and management of your dishwasher via the Home Connect app.

- **Home Connect:** home appliances with smart connectivity for an easier everyday life.
- **ExtraDry:** extra drying option for difficult-to-dry loads.
- **Flex baskets:** flexible and practical solution for easy loading.
- **InfoLight:** a red infolight on the floor indicates whether the dishwasher is switched on or off.
- **Silence on demand:** up to 30 min noise reduction at any time via the Home Connect App.

Technical Data

- Energy Efficiency Class: D
- Energy Consumption for 100 cycles Eco Programme: 84 kWh
- Maximum number of place settings: 13
- The water consumption of the eco programme in liters per cycle: 9.5 l
- Programme duration: 4:55 h
- Airborne acoustical noise emissions : 48 dB
- Airborne acoustical noise emission class: C
- Construction type: Built-in
- Height of removable worktop: 0 mm
- Dimensions of the product (HxWxD): 815 x 598 x 550 mm
- Required niche size for installation (HxWxD): 815-875 x 600 x 550 mm
- Approval certificates: CE, VDE
- Depth with open door 90 degree: 1150 mm
- Adjustable feet: Yes - all from front
- Maximum adjustability feet: 60 mm
- Adjustable plinth: both horizontal and vertical
- Net weight (kg): 33.812 kg
- Gross weight (kg): 36.0 kg
- Connection rating (W): 2400 W
- Fuse protection: 10 A
- Voltage (V): 220-240 V
- Frequency (Hz): 50; 60 Hz
- Length of electrical supply cord: 175 cm
- Plug type: GB plug
- Length inlet hose: 165 cm
- Length outlet hose: 190 cm
- EAN code: 4242005270330
- Installation type: Full-integrated



4 242005 270330

Serie | 2, Fully-integrated dishwasher, 60 cm SMV2HAX02G

Easy loading of dishes and management of your dishwasher via the Home Connect app.

New for 2021

Performance

- Energy Efficiency Class¹: D
- Energy² / Water³: 84 kWh / 9.5 litres
- Capacity: 13 place settings
- Programme duration⁴: 4:55 (h:min)
- Noise level: 48 dB(A) re 1 pW
- Noise Efficiency Class: C

Programmes / functions

- 5 programmes: Eco 50 °C, Auto 45-65 °C, Intensive 70 °C, Express 65°, Favourite
- Default favourite programme: Pre-Rinse
- 4 special options: Remote Start, Extra Dry, Half Load, SpeedPerfect+
- Machine Care
- Silence on Demand (via app)

Flexible design elements

- Flex basket system
- 3 stage Rackmatic height-adjustable top basket
- Low friction wheels on bottom basket
- Rack Stopper to prevent derailing of bottom basket
- 2 foldable plate racks in top basket
- 2 foldable plate racks in bottom basket
- Knife rack in top basket
- Moveable cutlery basket in lower rack
- Upper rack cup shelf

Innovations and technology

- Home Connect ready on WLAN
- Heat exchanger.
- DosageAssist detergent dispenser
- EcoSilence BLDC drive
- Automatic detergent detection
- Aqua and loading sensor
- AquaMix - Glass protection system

Design features

- Push button top edge controls
- InfoLight (Red) - Light projection on the floor
- Time delay (3, 6 or 9 hours)
- AquaStop: Bosch warranty in case of water damage - for the lifetime of the appliance. Please find warranty terms under <https://www.bosch-home.co.uk/customer-service/care-protection-and-parts/additional-warranties>
- Self-cleaning filter system with 3 piece corrugated filter
- Large item spray head, steam protection plate
- Stainless steel interior
- Dimensions (HxWxD): 81.5 x 59.8 x 55cm
- ¹ Scale of Energy Efficiency Classes from A to G
- ² Energy consumption in kWh per 100 cycles (in programme Eco 50 °C)
- ³ Water consumption in litres per cycle (in programme Eco 50 °C)
- ⁴ Duration of programme Eco 50 °C

Serie | 2, Fully-integrated dishwasher, 60 cm SMV2HAX02G

measurements in mm



socket
() values with extension kit

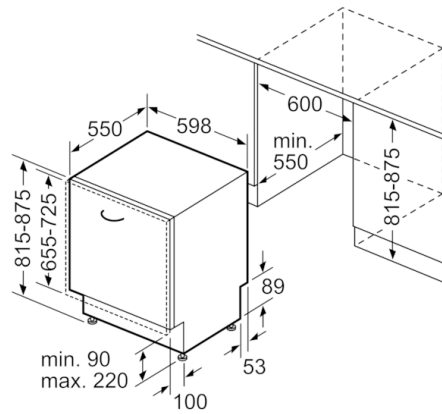

measurements in mm